

SWARCO

McCain 334 CONTROLLER CABINET



The McCain 334 Controller Cabinet is a versatile cabinet ideal for ramp metering and various other applications including highway surveillance, sign control, and sprinkler control. This cabinet, meeting all Caltrans and Federal Highway Administration (FHWA) requirements, offers standard input file and power assemblies and ample room for up to two controllers and other equipment. Its 19-inch Electronics Industry Alliance (EIA) rack and modular design allow for the easy interchange of standard assemblies and components.



KEY BENEFITS

- Meets all Caltrans and FHWA requirements
- Apply a variety of applications
- Allow easy access to the cabinet's large interior
- Accommodate two 170 or 2070 controllers with ample space
- Assure interchangeability between manufacturers with standard assemblies
- Provide maximum security using 3-point latching system with industry standard locks

PRODUCT DESCRIPTION

The McCain 334 Controller Cabinet's design allows the easy interchange of assemblies making it compatible with a gamut of applications including ramp metering, closed-circuit television, data acquisition, and surveillance.

Standard assemblies include a 14-position input file that accepts 2-channel or 4-channel detector modules and a PDA-3 assembly that is combined with a Model 206 24 VDC power supply and three load switch positions.

The cabinet's marine-grade aluminum exterior and thermostatically controlled ventilation protect your equipment from harsh and varying external elements and provide filtered air for the interior of the cabinet.

Secured via a 3-point latching system with industry standard locks on both doors, the McCain 334 Controller Cabinet is not only functional but secure.

McCain 334 CONTROLLER CABINET

FRONT

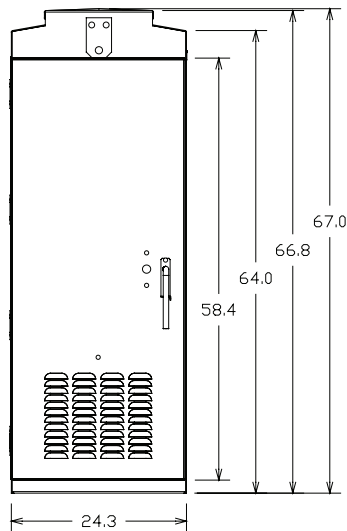

SIDE

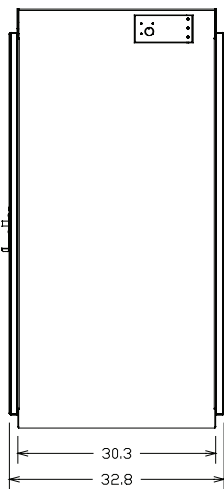

BOTTOM

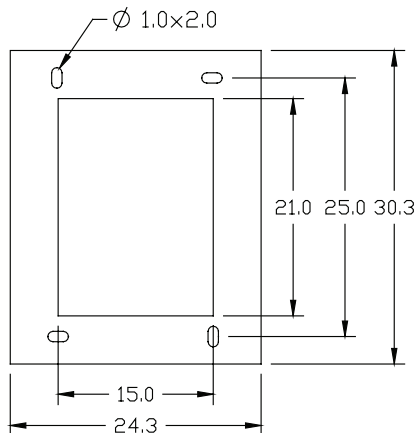

STANDARD FEATURES

- 3-phase operation
- 2-channel or 4-channel industry standard detection modules
- Detector input panel with terminal blocks or Panduit ducts

ASSEMBLIES AND COMPONENTS

- Up to 28 isolated inputs
- 9 AC switched outputs
- Combined PDA-3 power distribution assembly, Model 206 24 VDC plug-in power supply, and 3 load switch positions
- Service panel
- Controller shelf

GENERAL SPECIFICATIONS

Dimensions ¹ :	24"W x 67"H x 30"D
Material:	5052-H32 aluminum, 0.125" thick
Finishes:	Natural, anodized, or powder coated
Door:	Front door (1), back door (1), both full size
Latching System:	3-point, choice of Corbin or Best locks
Handles:	3/4" round, stainless steel, with padlock feature
Door Stops:	90° and 180° (±10°), each door, top and bottom
Rack Assembly:	Removable 19" EIA rack
Ventilation:	Thermostatically controlled 100 CFM fan, louvered air intake in door, pleated filter
Mounting:	Base mounted
Shipping Weight ² :	200 lbs

OPTIONS

- 3/4" x 16" anchor bolts for mounting (4)
- Fluorescent cabinet light(s) with door switch(es)
- Dual fans
- Communication panels
- External modems
- Pull-out drawer/shelf assembly
- Cabinet diagnostic kit
- Special configurations available
- 208 watch dog monitor
- Additional input files
- Police panel with lights "On/Off" and control "On/Off" switches
- Underwriter's Laboratories Listing (cabinet housing)

¹Dimensions rounded to the nearest inch

²Without plug-ins or controller(s)